



# VESUVIO C | CV



**FRANTOIO A MASCELLE**  
JAW CRUSHER  
BACKENBRECHER  
CONCASSEURS À MÂCHOIRE



**TRAMOGGIA DI CARICO**  
FEED HOPPER  
AUFGABEBUNKER  
TRÉMIE ALIMENTATION

2.000 x 3.960 mm - 4 m<sup>3</sup>

**ALIMENTATORE VIBRANTE  
A BARROTTI VERSIONE "C"**  
GRIZZLY FEEDER "C" VERSION  
STANGENVIBRATIONSAUFGEBER  
VERSION "C"  
SCALPEUR VIBRANT VERSION "C"

970 x 3.600 mm

**VAGLIO VIBRANTE A 2 PIANI  
VERSIONE "CV"**  
DOUBLE DECK VIBRATING  
SCREEN "CV" VERSION  
ZWEI DECKEN VIBRATIONSSIEB  
VERSION "CV"  
CRIBLE VIBRANT A DEUX ÉTAGES  
VIBRANT VERSION "CV"

1.020 x 1.800 mm

**NASTRO TRASPORTATORE  
PRINCIPALE**  
MAIN BELT CONVEYOR  
HAUPTFÖRDERBAND  
TRANSPORTEUR PRINCIPAL

800 x 9.600 mm

**CINGOLI**  
TRACKS  
RAUPENFAHRWERK  
CHENILLES

400 x 3.310

**DIMENSIONI DI TRASPORTO**  
TRANSPORT DIMENSIONS  
TRANSPORTABMESSUNGEN  
DIMENSIONS DE TRANSPORT

12.900 x 3.200 x 2.550 mm

**PESO (SENZA OPTIONALS)**  
WEIGHT  
GEWICHT  
POIDS

34.500 Kg **C**  
35.000 Kg **CV**

**DIMENSIONI DI TRASPORTO**  
TRANSPORT DIMENSIONS  
TRANSPORTABMESSUNGEN  
DIMENSIONS DE TRANSPORT

12.900 x 3.200 x 2.550 mm

**IMPIANTO ABBATTIMENTO POLVERI**  
DUST SUPPRESSION SYSTEM  
STAUBABSAUGUNG  
ABATTAGE DE POUSSIÈRE

**POMPA TRAVASO GASOLIO**  
DIESEL TANK FILLING PUMP  
DIESEL ÖLBEHALTERFÜLLPUMPE  
POMPE DE REMPLISSAGE RÉSERVOIR  
DE GASOIL

**SEPARATORE MAGNETICO**  
MAGNETIC BAND SEPARATOR  
MAGNETABSCHIEDER  
SÉPARATEUR

**OPTIONAL**

**RADIOCOMANDO LIV.1 - LIV.2**  
RADIO REMOTE CONTROL  
FERNSTEUERUNG  
COMMANDE À DISTANCE

**NASTRO LATERALE**  
SIDE BELT CONVEYOR  
SEITENAUSTRAGSFÖRDERER  
BANDE TRANSPORTEUSE LATÉRALE  
**600 x 4.500 mm**

**POMPA PER IMPIANTO  
ABBATTIMENTO POLVERI**  
WATER PUMP FOR DUST  
SUPPRESSION SYSTEM  
SELBSTANLASSENDE PUMPE  
FÜR STAUBABSAUGUNG  
POMPE POUR INSTALLATION  
D'ABATTAGE DE POUSSIÈRE

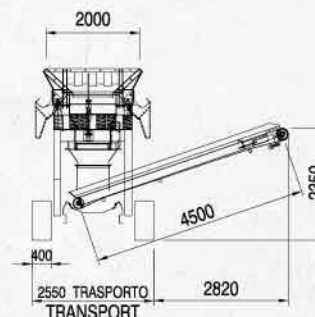
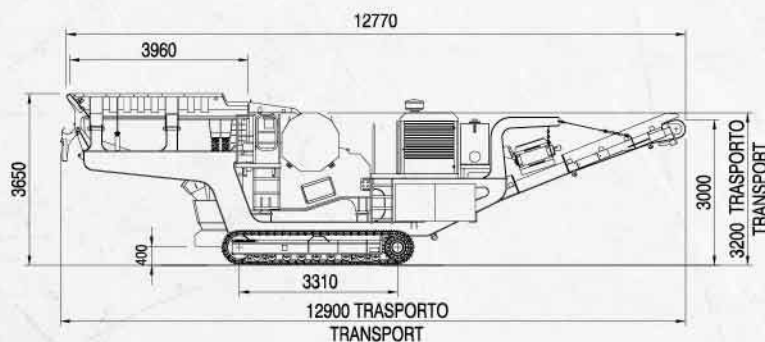

- \* La regolazione min. consentita è in funzione della durezza del materiale e del rapporto di riduzione.
- \* The minimum c. s. s. varies in function of the material hardness and of the reduction ratio.
- \* Die minimale Einstellung hängt von der Härte von Baustoffen und vom dimensionalen Beziehung des Produktes beim Eingang und beim Verlassen des Brechers ab.
- \* Le réglage minimum dépend par la dureté des matériaux et par le rapport dimensionnel du produit à l'entrée et à la sortie du concasseur.

Via Giorgione, 17 - S.S. Feltrina  
T +39 0423 670201  
F +39 0423 676575

www.gasparin-omg.com  
info@gasparin-omg.com

PRODUCTIVE UNIT  
Via Palladio, 29  
T +39 0423 670001  
F +39 0423 670602  
31040 Musano di Trevignano  
(Treviso) Italy



YOUR PARTNER IN CRUSHING & SCREENING

